

JOB NAME: \_\_\_\_\_

DATE: \_\_\_\_\_

TYPE: \_\_\_\_\_

**DIMENSIONS:**

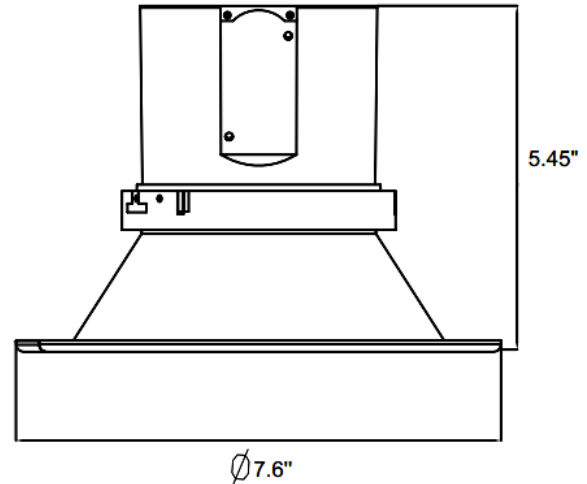

- CRLC6-15W-30K-D    CRLC6-15W-30K-D-WH
- CRLC6-15W-60K-D    CRLC6-15W-40K-D-WH
- CRLC6-15W-50K-D    CRLC6-15W-50K-D-WH

**6" LED COMMERCIAL RECESSED LIGHT**

Ideal for hotel, offices, retail outlets, restaurant, parking garages, conference room, education facilities and more.

**ELECTRICAL SPECIFICATIONS:**

- Voltage: 120-277VAC 50/60Hz
- Wattage: 15W
- Power factor: >0.90
- Efficacy: 80~85LM/W

**HOUSING SPECIFICATIONS:**

- 6" Haze & White Finish TRIM
- Mounting Options: Recessed
- Temperature Rating: Designed to operate in temperatures 113°F
- No IC-Rated
- Lifespan: 50,000 hrs.
- Suitable for Damp Locations

**CERTIFICATIONS: UL**



MODEL	WATTS	VOLTAGE	LUMENS	COLOR TEMP	FINISH
CRLC6-15W-30K-D	15W	120~277VAC	1200LM	3000K	HAZE
CRLC6-15W-40K-D	15W	120~277VAC	1245LM	4000K	HAZE
CRLC6-15W-50K-D	15W	120~277VAC	1275LM	5000K	HAZE
CRLC6-15W-30K-D-WH	15W	120~277VAC	1200LM	3000K	WHITE
CRLC6-15W-40K-D-WH	15W	120~277VAC	1245LM	4000K	WHITE
CRLC6-15W-50K-D-WH	15W	120~277VAC	1275LM	5000K	WHITE

**LIGHTING SPECIFICATIONS:**

- Dimming: 0~10V Dimmable
- Recommended Dimmers: DVTV(LUTRON),IP710(LEVITON)
- Total lumens: 1200~1275LM
- Color temperature: 5000K/4000K/3000K
- Color rendering index: >80

**WARRANTY: 5 years**



JOB NAME: \_\_\_\_\_

DATE: \_\_\_\_\_

TYPE: \_\_\_\_\_

**CRLC6-15W-30K-D CRLC6-15W-30K-D-WH**  
**CRLC6-15W-40K-D CRLC6-15W-40K-D-WH**  
**CRLC6-15W-50K-D CRLC6-15W-50K-D-WH**

**6" LED COMMERCIAL RECESSED LIGHT**

**PHOTOMETRY CHART:**

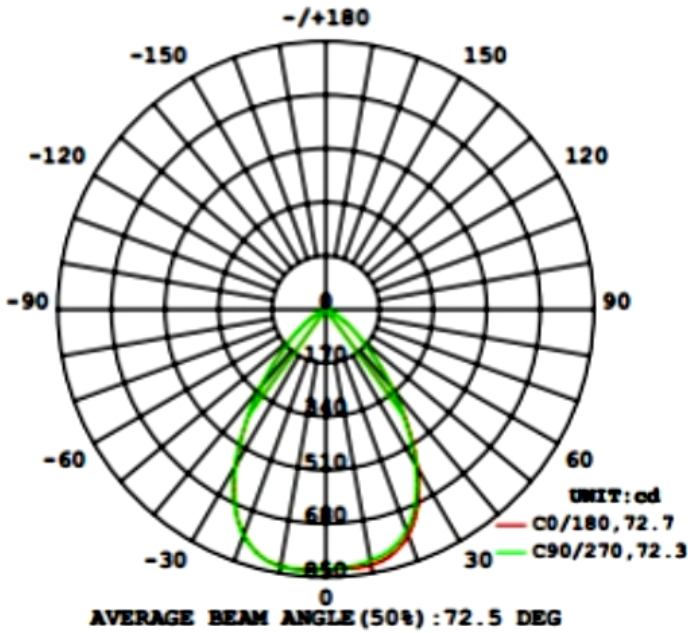

MODEL	WATTS	VOLTAGE	LUMENS	COLOR TEMP	FINISH
CRLC6-15W-30K-D	15W	120~277VAC	1200LM	3000K	HAZE
CRLC6-15W-40K-D	15W	120~277VAC	1245LM	4000K	HAZE
CRLC6-15W-50K-D	15W	120~277VAC	1275LM	5000K	HAZE
CRLC6-15W-30K-D-WH	15W	120~277VAC	1200LM	3000K	WHITE
CRLC6-15W-40K-D-WH	15W	120~277VAC	1245LM	4000K	WHITE
CRLC6-15W-50K-D-WH	15W	120~277VAC	1275LM	5000K	WHITE

**TWO WAYS TO ORDER :**



1.ORDER COMPLETE	2.ORDER ENGINE & TRIM SEPARATELY		
	UNIT	ENGINE	TRIM
CRLC6-15W-30K-D	CRLC-ENG-15W-30K-D	+	CRLC-TRM-6
CRLC6-15W-40K-D	CRLC-ENG-15W-40K-D	+	CRLC-TRM-6
CRLC6-15W-50K-D	CRLC-ENG-15W-50K-D	+	CRLC-TRM-6
CRLC6-15W-30K-D-WH	CRLC-ENG-15W-30K-D	+	CRLC-TRM-6-WH
CRLC6-15W-40K-D-WH	CRLC-ENG-15W-40K-D	+	CRLC-TRM-6-WH
CRLC6-15W-50K-D-WH	CRLC-ENG-15W-50K-D	+	CRLC-TRM-6-WH

